

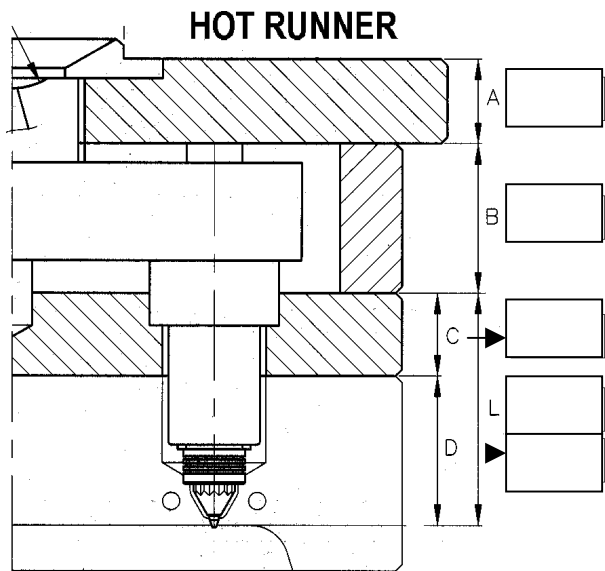

# STM WEB SITE ORDER/ENQUIRY FORM

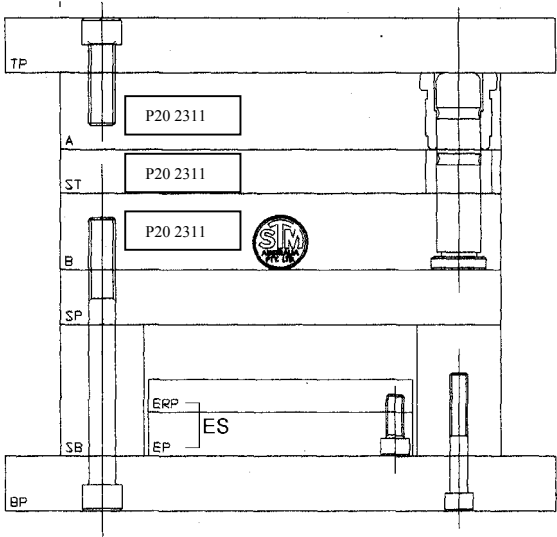

<b>Company:</b>	<b>Date:</b>
<b>Address:</b>	<b>Phone:</b>
<b>Order No:</b>	<b>Fax:</b>
<b>Mould Base Size:</b>	<b>Job No:</b>
<b>Contact:</b>	



**GENERAL COMMENTS...**

DESCRIPTION	SIZE	QTY	DEL
<b>MOULD BASE</b>			
Fixed Clamp Plate	TP X X		
Fixed Cavity Plate	A X X		
Stripper Plate	ST X X		
Moving Core Plate	B X X		
Support Plate	SP X X		
Spacer Blokes	SB Height		
Ejector Set	ES		
Moving Clamp Plate	BP X X		
<b>COMMENTS</b>			
<b>ANCILLARIES</b>			
Manifold			
Hot Nozzles			
Power Connection			
T/C Connector			
Terminal Box			
Temp Controllers			
Location Ring			
Cold Sprue Bush			
Return Pins			
Springs			
Sprue Puller Pin			
Ejector Guide Pin			
Ejector Guide Bush			
Tapered Interlocks			
Date Stamp			
Ejector Pin			
Ejector Sleeve			
Ejector Blade			
<b>OTHER</b>			
(ie. Water Fittings, Screws, Dowls etc.)			

